

Lithium-ion BMS boards for

- Electric vehicles
- Hybrid vehicles
- Industrial machines
- Marine vessels
- Energy storage

INTRODUCTION

The s-BMS is an exceptionally flexible and cost effective Battery Management System for automotive, industrial and stationary battery packs ranging from 12VDC up to 1000VDC. It manages rechargeable lithium batteries of any chemistry and from any battery supplier allowing you maximum battery sourcing freedom.

The system consists of a master board (BMCU) communicating with up to 32 monitoring boards (LMU). Each LMU manages 3–8 cells in series and 2 temperature sensors. The BMCU handles pack level measurements, data logging, application and charger interfaces.

The PC Diagnostic Software provides an intuitive suite of system configuration tools as well as displays for monitoring battery and BMS performance. It allows you to set battery parameters such as limit voltages and temperatures, allowable charge and discharge rates or improve SoC estimation with your own battery model.

To simplify integration CAN frames can be constructed at “Bit level” to broadcast any of the parameters measured and calculated by the s-BMS. A post processing module allows you to scale and manipulate values and broadcast them on the CAN bus with no custom development needed. This allows the s-BMS to work as a drop in replacement for many existing systems.

FLEXIBILITY

- 12 VDC to 1000 VDC
- Up to 256 cells in series
- All battery parameters easily configured
- User-definable event responses and warnings
- User configurable I/Os and CAN messages
- Battery model for intelligent rate control
- Embedded post processing of CAN values

SAFETY

- Detection of 27 error modes and 17 warning conditions
- Noise and vibration robust
- 40° to +85°C operational range

FUNCTIONALITY

- Cell voltages 0-5V, $\pm 2\text{mV}$ accuracy
- SOC and SOH estimation
- LEAK detection
- Cell balancing up to 840mA/cell
- Cell and Pack resistance estimation
- Thermal management
- Advanced charger control
- Data Logging

TESTED TO HELL SO YOU CAN USE IT ON EARTH WITH CONFIDENCE!

- Electromagnetic interference >200 volts/m
- Fast transients 4kV on all inputs
- HALT tested on all 3 vibration axes
- Tested from -90°C up to 120°C



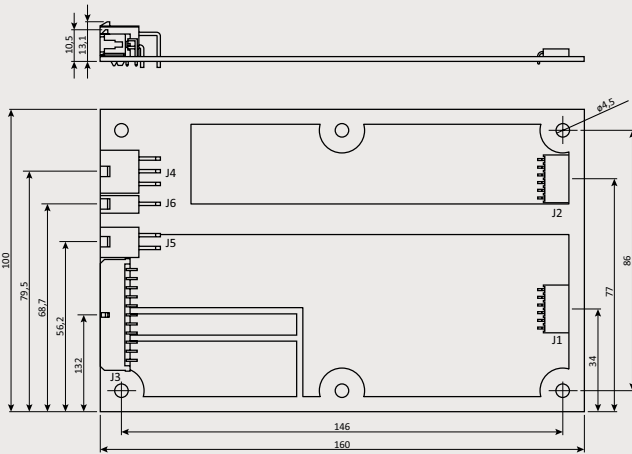

BMCU

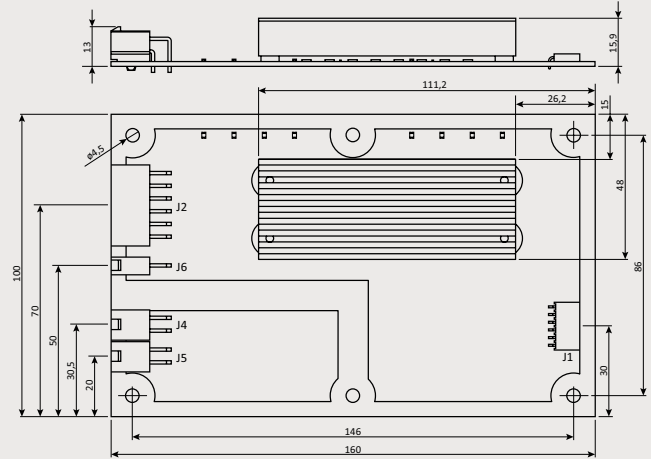

LMU

System Voltage Range	12 - 1000VDC
Cells per LMU	3-8 Cells
Cells per System	3 - 256 Cells in series
Capacity	Upto 2000 Ah
Balancing Current	Up to 840mA @ 4.2VDC (Optional Heat Sink for boosted performance)
Input Voltage	12 VDC (9VDC - 14VDC)
Current Consumption: BMCU	<150mA operating
Current Consumption: LMU	<10mA operating. LMU is powered from cells
Temperature Sensor	2 On board + 2 NTC, 10KΩ @ 25 DegC, β Value: 3900 per Unit
Measurement Specifications	Cell Voltage: Range 0-5V, Accuracy ±2mV typical, <±10mV max., Sampling 1Hz Temperature accuracy ±1.5°C (dependent on sensor) Pack voltage 0-1000V, accuracy ±1V, Sampling 5Hz Current Measurement by Shunt (100 – 1000 μΩ), 400mV max, Sampling 5Hz
Dimensions	160 x 100 mm (Eurocard size), 20 mm stacking height
Coating	BMCU 86g, LMU 72g, LMU with optional heatsink 146g
Control IOs	3M™ Novec™ Electronic Coating EGC-1700
User Defined IOs (max. 3)	HV Contactors, Charge Contactor, Precharge Contactor
Communication	Fan Control, Heater Control, HV Interlock, Low SOC Warning, Mid Pack Relays Error LED, Off Board Leak Detect., Low Power Charger Mode (e.g. dual chargers) CAN bus 2.0 A&B for system integration RS232 PC diagnostics interface
Charger Control Options	Analogue voltage control, PWM 1-5 KHz, CAN 2.0 A&B
Protection Modes	Capable to monitor and handle 27 safety critical error modes Capable to report 17 unique warnings conditions Capability to broadcast system status, errors and warnings over CAN
Diagnostic Tool	Licensing via USB Dongle (allowing multiple device usage) Supported Operating Systems: Windows Professional, XP, Vista, 7, 8 Pro Version - Calibration Development capability Service Version - Field Service & troubleshooting
EMC Immunity	Requires USB to RS 232 converter cable or RS232 port on device
Temperature	Tested as per EN61000-4-3 (80MHz – 1000MHz) at 200 V/m, EN61000-4-4 (4kV)
Vibration Tolerance	Specifications: Operational -40° to 85°C Tested as per EN60068-2-6 random vibration (10 – 1000Hz)
Certifications	CE marking
Patents	U.S. Patent No. 8,350,529. China Patent No. ZL 2007 8 0048774.x Patents pending

